

## Magnum 400RD

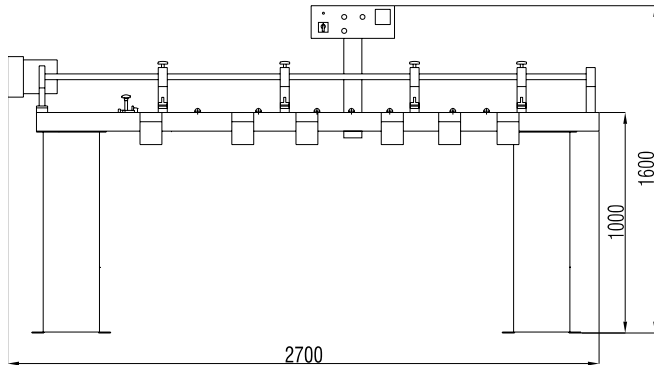

Machine type	M400RD
Wood slats width	25 mm, 35 mm, 50 mm
Max. length of wood slat	2500 mm
Number of punching stations	4
Min. distance from slat edge to first hole	70 mm
Power supply	3x400 V / 50-60 Hz
Installed power	0,75 kW
Net weight	160 kg
Gross weight	310 kg
Packing - 1 wood box	L = 2750 mm W = 670 mm H = 1670 mm

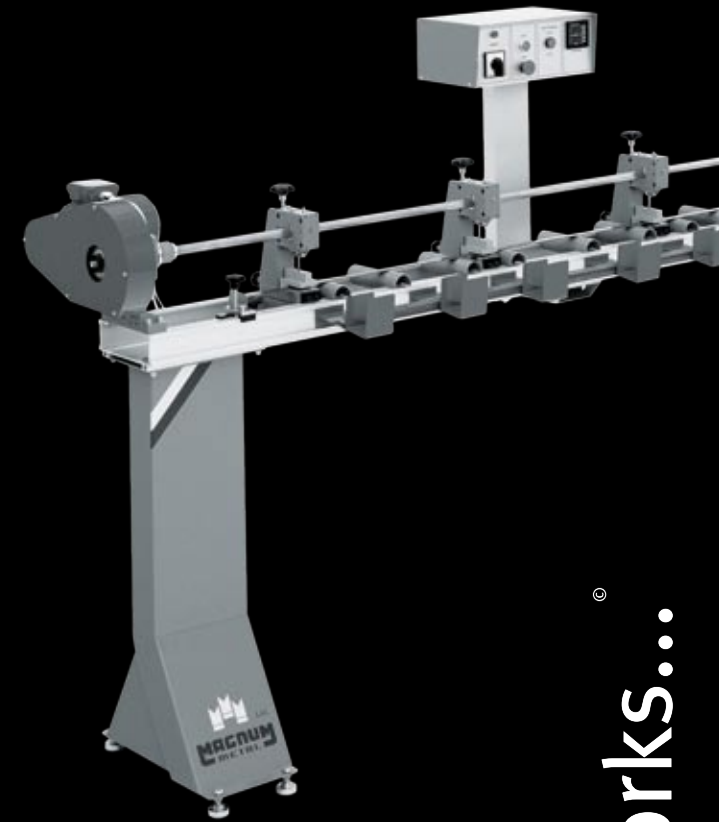

Magnum-Metal Sp. z o.o.  
ul. Szadkowska 72  
98-220 Zduńska Wola  
Poland

tel. +48 (0) 43 823 51 27  
fax +48 (0) 43 823 23 16

e-mail: [magnum@magnum-metal.pl](mailto:magnum@magnum-metal.pl)  
<http://www.magnum-metal.pl/>



Magnum 400RD

I ❤️ the way it works...<sup>©</sup>



## Magnum 400RD

Semi-automatic machine for wood slats

The semi-automatic machine type **M400 RD** is designed for punching of holes in wood slats of 25 mm or 35 mm or 50 mm width. Punching of holes is performed by means of foot-operated pedal, which releases the single turn of the punching dies drive shaft. Placing of slats in punching section and removing of pocket is made manually.

### Dimensions of standard holes (In relation to width of wood slats)

- 25 mm - 3 mm x 12 mm
- 35 mm - 4 mm x 15 mm
- 50 mm - 4 mm x 20 mm

Special dimensions of holes available on request.

### ADDITIONAL EQUIPMENT

- Punching stations for side guiding holes

You can find in our offer various machines for wood blinds production:

- manual
- semi-automatic
- automatic.