

## Magnum 450

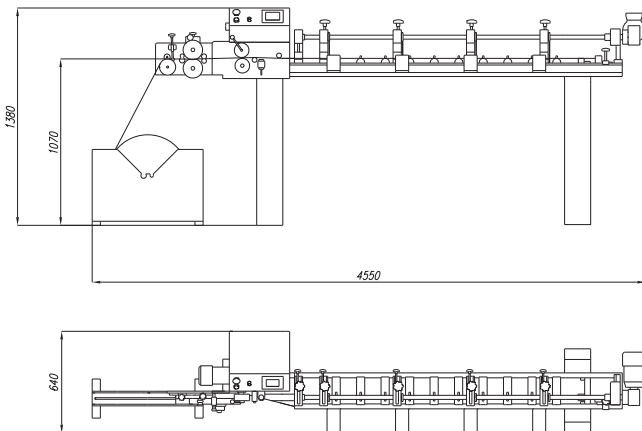

Machine type	M450
Slat width	16 mm or 25 mm
Cutting length	210 mm - 3000 mm
Number of punching stations	4
Number of cut off stations	1
Min. distance from slat edge to first hole	70 mm
Max. slat feeding speed	1,7 m/sec.
Power supply	230 V / 50-60 Hz
Installed power	0,95 kW
Net weight	190 kg
Gross weight	490 kg
Packing – wood crate	L = 4140 mm W = 730 mm H = 1630 mm

Magnum-Metal Sp. z o.o.  
ul. Szadkowska 72  
98-220 Zduńska Wola  
Poland

tel. +48 (0) 43 823 51 27  
fax +48 (0) 43 823 23 16

e-mail: [magnum@magnum-metal.pl](mailto:magnum@magnum-metal.pl)  
<http://www.magnum-metal.pl/>

General dealer:

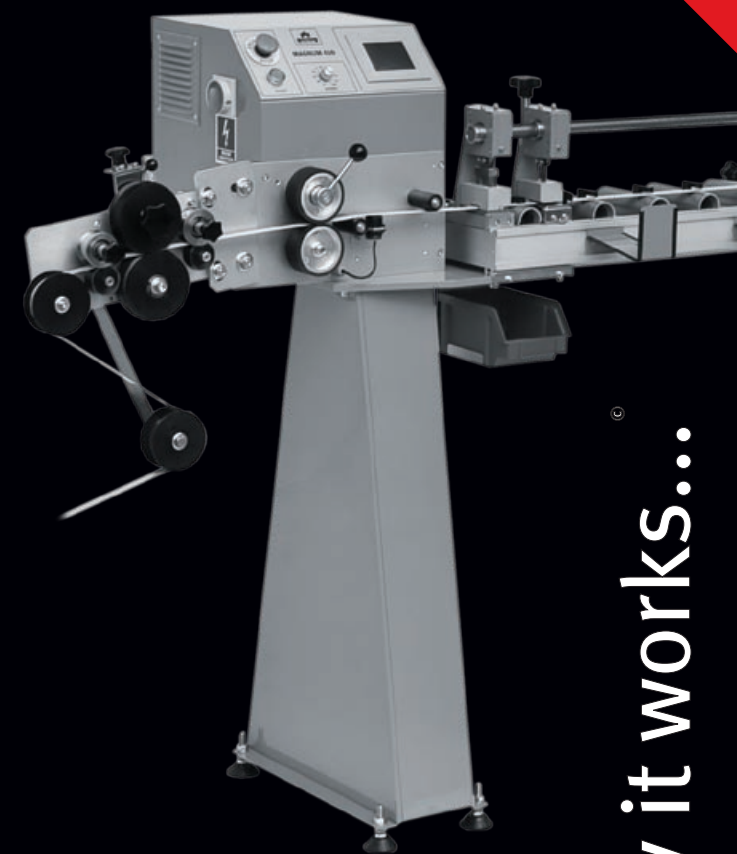

**NEW!**

I ❤️ the way it works...

**MAGNUM**  
METAL Ltd.

Magnum 450

**NEW!**

machine in the picture may be fitted with additional equipment



Control panel

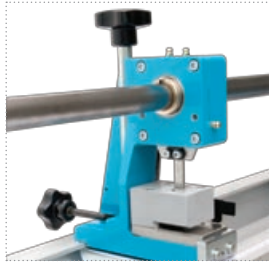

Punching unit

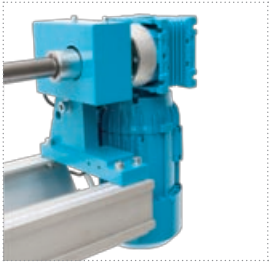

Punching units drive

## Magnum 450

### Semi automatic slat cutting and punching machine

Using our many years wide experience on blinds market and customers needs, machine range was replenished about new **M450** model designed for small and medium blinds manufacturers.

#### Features:

- Forming, cutting and hole punching in aluminum slat
- Easy setting of slat length and punching stations
- Variable speed 0-100%
- Slat width range 16 mm, 25 mm
- Quick and easy change between slat widths
- Automatic slat counting during production process
- Efficient "touch screen" control panel

#### Additional equipment:

- Side guide cut off die
- After sales support
- 25 mm or 16 mm slat width equipment